

MINIMAT-E Screwdriver Spindles

The electric screwdriver with mechanical shut-off clutch.

Torque range from 0.1 - 4.8 Nm

- **robust, long life cycle**
- **brushless electric drive**
- **lowest maintenance requirements**
- **highest shut-off accuracy**
- **highest process reliability**

The MINIMAT-E screwdriver operates using the well-established principle of the mechanical MINIMAT shut-off clutch. Using the shut-off clutch guarantees torque accuracy of 3% standard deviation, irrespective of the screw joint. The high precision shut-off clutch guarantees a high screw assembly quality with low maintenance requirements over a cycle of a million screw assemblies.

The strength of the MINIMAT-E spindle screwdriver lies in the screw assembly torque range of 0.1 Nm to 4.8 Nm. High speeds of 650 up to 2000 rpm secure short cycle times.



MINIMAT-E SCREWDRIVER SPINDLE

Working Principle

The MINIMAT-E screwdriver operates using the well-established principle of the mechanical MINIMAT shut-off clutch. Using the shut-off clutch guarantees torque accuracy of 3% standard deviation, irrespective of the screw joint.

However, in many cases even better accuracy can be achieved so that under certain conditions a machine capability index of ≥ 1.67 can be attained even with a tolerance requirement of $\pm 10\%$.

This means that the error rate is less than 0.6 per million screw assemblies. For further enhancement of the processing reliability the screw-in depth and screwdriver shut-off can additionally be monitored.

Depending on application case very short cycle times can be achieved as this screwdriver runs at maximum speed right up to the shut-off point of the clutch. Whereas in order to reach the stated accuracy other controlled screwdrivers are subject to a speed reduction before shut-off.

The screwdriver is designed for tough industrial use with high quality, robust system components guaranteeing reliability and a long life-span.

The maintenance free brushless EC drive provides outstanding dynamics and high maximum torque which is ideal for screw tightening.

The screwdriver is available with push-to-start or remote start PLC signal.

The options for inserting tools and additional components such as guide sleeves or vacuum connections are designed in the same way as the DEPRAG MINIMAT pneumatic screwdriver motor size 2 so that identical accessories may be used.

Axial spring loaded suspension

Due to the axial movement of the entire screwdriver in the screwdriver fixture a spring loaded drive element is not required.

Therefore low-priced standard inserting tools can be used.

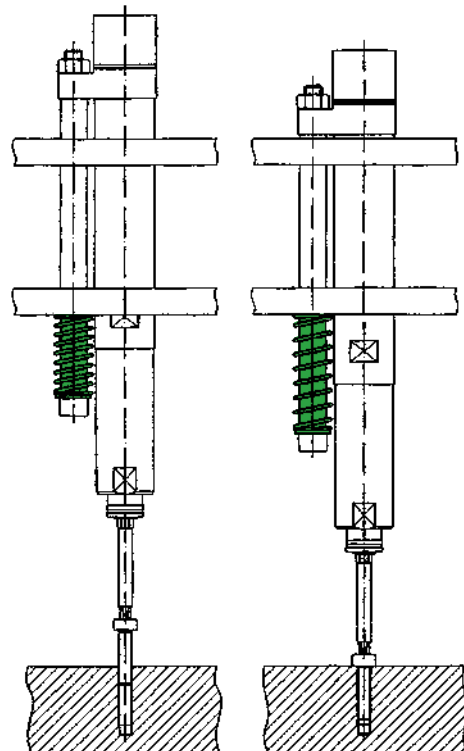

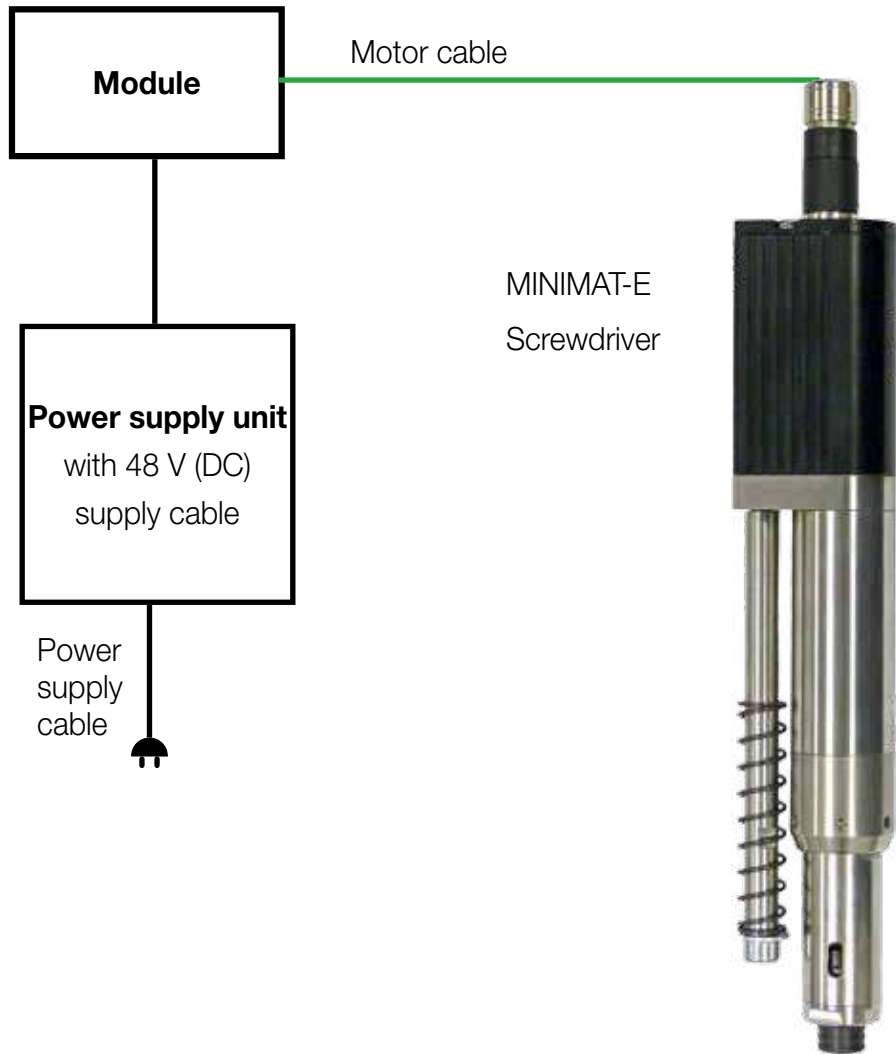

TECHNICAL DATA MINIMAT-E SCREWDRIVER, STATIONARY, STRAIGHT SPINDLE FORM

Spindle, remote start		Type	342EF27-0005-200	342EF27-0005-100	342EF27-0005-65	342EF27-0012-100	342EF27-0012-65
reversible, right shut-off		Part no.	308000A	308000B	308000C	308001A	308001B
Torque min.	Nm/in.lbs	0.1/0.885				0.4/3.54	
Torque max.	Nm/in.lbs	0.5/4.43				1.2/10.62	
Speed	rpm	2000	1000	650	1000	650	
Diameter	mm/in.	27/1.05	27/1.05	27/1.05	27/1.05	27/1.05	
Length	mm/in.	271/10.57	271/10.57	271/10.57	287/11.2	287/11.2	
Weight	kg/lbs	0.75/1.65	0.75/1.65	0.75/1.65	0.9/1.98	0.9/1.98	
Noise level	dB (A)	68	68	68	68	68	
Line voltage (DC)	V	48	48	48	48	48	
Spindle output		4 mm half moon	4 mm half moon	4 mm half moon	-	-	
Suitable inserting tools and connection parts with inserting end		4 mm half moon	4 mm half moon	4 mm half moon	-	-	
Internal hex. drive DIN ISO 1173					F6.3 (1/4")	F6.3 (1/4")	
Suitable inserting tools and connection parts with inserting end DIN ISO 1173		-	-	-	E6.3 (1/4")	E6.3 (1/4")	

Required accessories

Motor cable (2m/6.56ft.)	Type	KS4-2m	KS4-2m	KS4-2m	KS4-2m	KS4-2m
	Part no.	151515A	151515A	151515A	151515A	151515A
Alternative motor cable (5m/16.4ft.)	Type	KS4-5m	KS4-5m	KS4-5m	KS4-5m	KS4-5m
	Part no.	151515B	151515B	151515B	151515B	151515B
Power unit	Type	NG18	NG18	NG18	NG18	NG18
	Part no.	101067	101067	101067	101067	101067
Source (AC)	V/Hz	100-240/50-60	100-240/50-60	100-240/50-60	100-240/50-60	100-240/50-60
Output (DC)	V	48	48	48	48	48
Dimensions L x W x H	mm/in.	170x85x42 / 6.6 x 3.3 x 1.6				170x85x42 / 6.6 x 3.3 x 1.6
Weight	kg/lbs	0.85 / 1.87	0.85 / 1.87	0.85 / 1.87	0.85 / 1.87	0.85 / 1.87
Power cable EU	Type	KN-C13/EU	KN-C13/EU	KN-C13/EU	KN-C13/EU	KN-C13/EU
	Part no.	833790 (2m)	833790 (2m)	833790 (2m)	833790 (2m)	833790 (2m)
alternative:						
Power cable US	Type	KN-C13/US	KN-C13/US	KN-C13/US	KN-C13/US	KN-C13/US
	Part no.	833791 (2m)	833791 (2m)	833791 (2m)	833791 (2m)	833791 (2m)
Power cable UK	Type	KN-C13/UK	KN-C13/UK	KN-C13/UK	KN-C13/UK	KN-C13/UK
	Part no.	833792 (2m)	833792 (2m)	833792 (2m)	833792 (2m)	833792 (2m)
Power cable Brazil	Type	KN-C13/BR	KN-C13/BR	KN-C13/BR	KN-C13/BR	KN-C13/BR
	Part no.	207388 (1.8m)	207388 (1.8m)	207388 (1.8m)	207388 (1.8m)	207388 (1.8m)
Power cable China	Type	KN-C13/CN	KN-C13/CN	KN-C13/CN	KN-C13/CN	KN-C13/CN
	Part no.	832927(2.5m)	832927(2.5m)	832927(2.5m)	832927(2.5m)	832927(2.5m)
Module	Part no.	100901A	function: supply of the signals - screwdriver running, - screwdriver start and reverse			

Optional equipment

Spring sleeve cpl.	Part no.	4032801B	364672A
Spring sleeve cpl., with vacuum connection (in connection with finder, see leaflet: Inserting tools D3320E)	Part no.	4032801B	364672C

The MINIMAT-E screwdriver spindle in comparison to the pneumatic screwdriver of the DEPRAG series MINIMAT, motor size 2

MINIMAT
pneumatic
screwdriver spindle,
motor size 2

MINIMAT-E
electric screwdriver spindle
with mechanical shut-off
clutch
Spindle output:
Internal hex. drive
DIN 1173, F6.3 (1/4")

MINIMAT-E
electric screwdriver spindle
with mechanical shut-off
clutch
Spindle output:
4 mm half moon

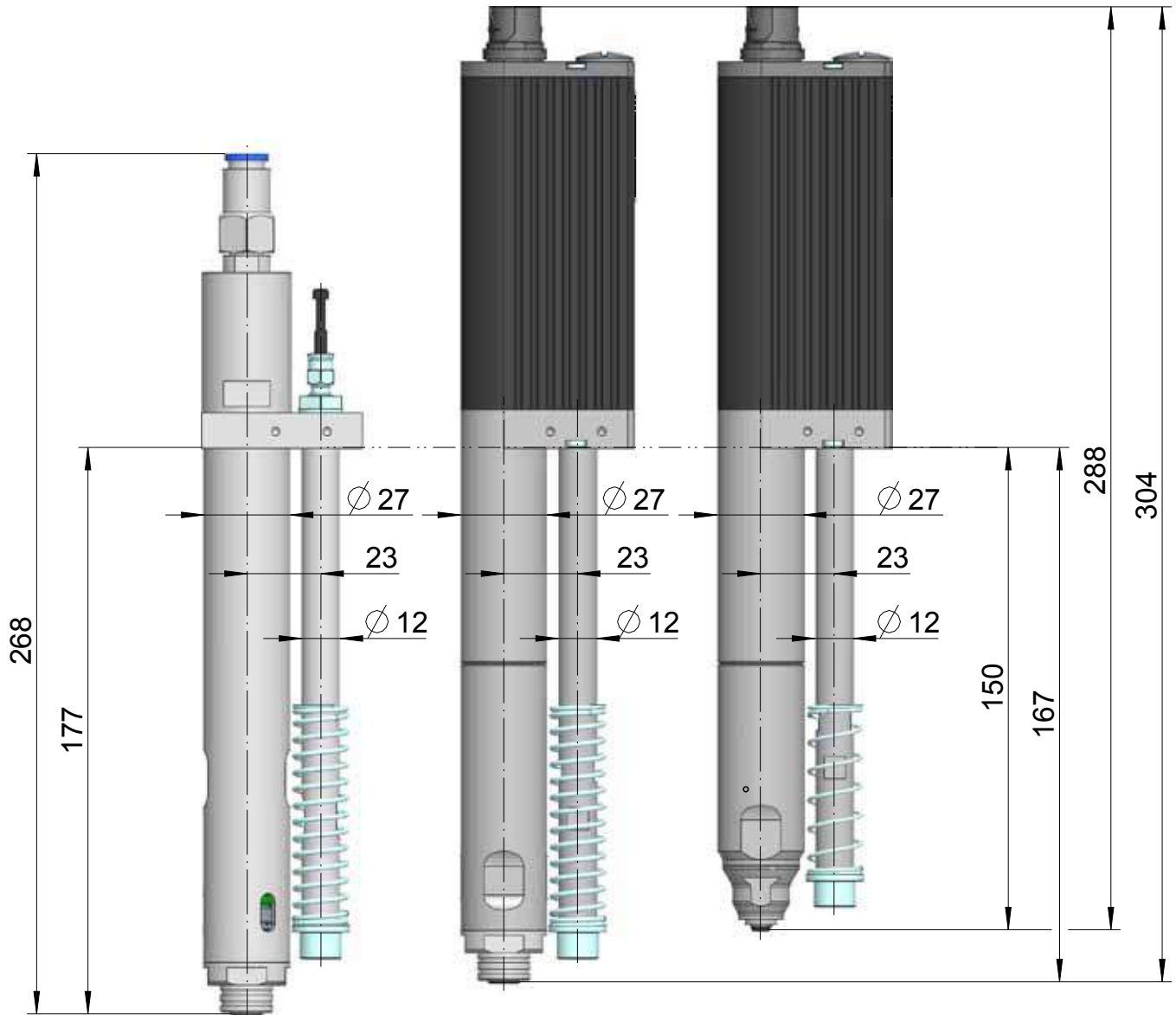

TECHNICAL DATA MINIMAT-E SCREWDRIVER, STATIONARY, STRAIGHT SPINDLE FORM

Spindle, push to start right rotation, right shut-off	Type Part no.	342EA36-0009-200 304001A	342EA36-0009-100 304001B	342EA36-0009-65 304001C	342EA36-0018-200 304004A	342EA36-0018-100 304004B	342EA36-0018-65 304004C
Spindle, remote start reversible, right shut-off	Type Part no.	342EF36-0009-200 305001A	342EF36-0009-100 305001B	342EF36-0009-65 305001C	342EF36-0018-200 305004A	342EF36-0018-100 305004B	342EF36-0018-65 305004C
Torque min.	Nm/in.lbs	0.4 / 3.5			0.5 / 4.4	0.4 / 3.5	0.4 / 3.5
Torque max.	Nm/in.lbs	0.9 / 8			1.8 / 16		
Speed	rpm	2000	1000	650	2000	1000	650
Diameter	mm/in.	36 / 1.4	36 / 1.4	36 / 1.4	36 / 1.4	36 / 1.4	36 / 1.4
Length	mm/in.	283 / 11	283 / 11	283 / 11	283 / 11	283 / 11	283 / 11
Weight	kg/lbs	1 / 2.2	1 / 2.2	1 / 2.2	1 / 2.2	1 / 2.2	1 / 2.2
Noise level	dB (A)	68	68	68	68	68	68
Line voltage (DC)	V	48	48	48	48	48	48
Internal hex. drive DIN ISO 1173		F6.3 (1/4")	F6.3 (1/4")	F6.3 (1/4")	F6.3 (1/4")	F6.3 (1/4")	F6.3 (1/4")
Suitable inserting tools and connection parts with inserting end DIN ISO 1173		E6.3 (1/4")	E6.3 (1/4")	E6.3 (1/4")	E6.3 (1/4")	E6.3 (1/4")	E6.3 (1/4")
Spindle, push to start right rotation, right shut-off	Type Part no.	342EA36-0024-100 304002A	342EA36-0024-65 304002B	342EA36-0036-65 304003A	342EA36-0048-100 304005A	342EA36-0048-65 304005B	
Spindle, remote start reversible, right shut-off	Type Part no.	342EF36-0024-100 305002A	342EF36-0024-65 305002B	342EF36-0036-65 305003A	342EF36-0048-100 305005A	342EF36-0048-65 305005B	
Torque min.	Nm/in.lbs	0.4 / 3.5		0.5 / 4.4	0.4 / 3.5	0.4 / 3.5	
Torque max.	Nm/in.lbs	2.4 / 21.24		3.6 / 31.86	4.8 / 42.48		
Speed	rpm	1000	650	650	1000	650	
Diameter	mm/in.	36 / 1.4	36 / 1.4	36 / 1.4	36 / 1.4	36 / 1.4	
Length	mm/in.	283	283	283	283	283	
Weight	kg/lbs	1 / 2.2	1 / 2.2	1 / 2.2	1 / 2.2	1 / 2.2	
Noise level	dB (A)	68	68	68	68	68	
Line voltage (DC)	V	48	48	48	48	48	
Internal hex. drive DIN ISO 1173		F6.3 (1/4")	F6.3 (1/4")	F6.3 (1/4")	F6.3 (1/4")	F6.3 (1/4")	
Suitable inserting tools and connection parts with inserting end DIN ISO 1173		E6.3 (1/4")	E6.3 (1/4")	E6.3 (1/4")	E6.3 (1/4")	E6.3 (1/4")	

Required accessories

Motor cable (2m/6.56ft.)	Type Part no.	KS4-2m 151515A	KS4-2m 151515A	KS4-2m 151515A	KS4-2m 151515A	KS4-2m 151515A	KS4-2m 151515A
Alternative motor cable (5m/16.4ft.)	Type Part no.	KS4-5m 151515B	KS4-5m 151515B	KS4-5m 151515B	KS4-5m 151515B	KS4-5m 151515B	KS4-5m 151515B
Alternative motor cable (8m/26.24ft.)	Type Part no.	KS4-8m 151515C	KS4-8m 151515C	KS4-8m 151515C	KS4-8m 151515C	KS4-8m 151515C	KS4-8m 151515C
Power unit	Type Part no.	NG18 101067	NG18 101067	NG18 101067	NG300 126423A	NG300 126423A	NG300 126423A
Source (AC)	V/Hz	100-240/50-60	100-240/50-60	100-240/50-60	90-264/47-63	90-264/47-63	90-264/47-63
Output (DC)	V	48	48	48	48	48	48
Dimensions L x W x H	mm/in.	170x85x42 / 6.6 x 3.3 x 1.6			197.4 x 88.9 x 39 / 7.7 x 3.5 x 1.5		
Weight	kg/lbs	0.85 / 1.87	0.85 / 1.87	0.85 / 1.87	1.34 / 2.95	1.34 / 2.95	1.34 / 2.95
Power cable EU	Type Part no.	KN-C13/EU 833790 (2m)	KN-C13/EU 833790 (2m)	KN-C13/EU 833790 (2m)	KN-C13/EU 833790 (2m)	KN-C13/EU 833790 (2m)	KN-C13/EU 833790 (2m)
alternative:							
Power cable US	Type Part no.	KN-C13/US 833791 (2m)	KN-C13/US 833791 (2m)	KN-C13/US 833791 (2m)	KN-C13/US 833791 (2m)	KN-C13/US 833791 (2m)	KN-C13/US 833791 (2m)
Power cable UK	Type Part no.	KN-C13/UK 833792 (2m)	KN-C13/UK 833792 (2m)	KN-C13/UK 833792 (2m)	KN-C13/UK 833792 (2m)	KN-C13/UK 833792 (2m)	KN-C13/UK 833792 (2m)
Power cable Brazil	Type Part no.	KN-C13/BR 207388 (1.8m)	KN-C13/BR 207388 (1.8m)	KN-C13/BR 207388 (1.8m)	KN-C13/BR 207388 (1.8m)	KN-C13/BR 207388 (1.8m)	KN-C13/BR 207388 (1.8m)
Power cable China	Type Part no.	KN-C13/CN 832927(2.5m)	KN-C13/CN 832927(2.5m)	KN-C13/CN 832927(2.5m)	KN-C13/CN 832927(2.5m)	KN-C13/CN 832927(2.5m)	KN-C13/CN 832927(2.5m)
Module suitable for spindle with remote start	Part no.	100901A	function: supply of the signals - screwdriver running, - screwdriver start and reverse				
Module suitable for spindle with push to start	Part no.	100901B	function: supply of the signal - screwdriver running				

Optional equipment

Spring sleeve cpl.	Part no.	364672A
Spring sleeve cpl., with vacuum connection (in connection with finder, see leaflet: Inserting tools D3320E)	Part no.	364672C

The MINIMAT-E screwdriver spindle in comparison to the pneumatic screwdriver of the DEPRAG series MINIMAT, motor size 3

MINIMAT

pneumatic screwdriver spindle,
motor size 3

MINIMAT-E

electric screwdriver spindle
with mechanical shut-off clutch

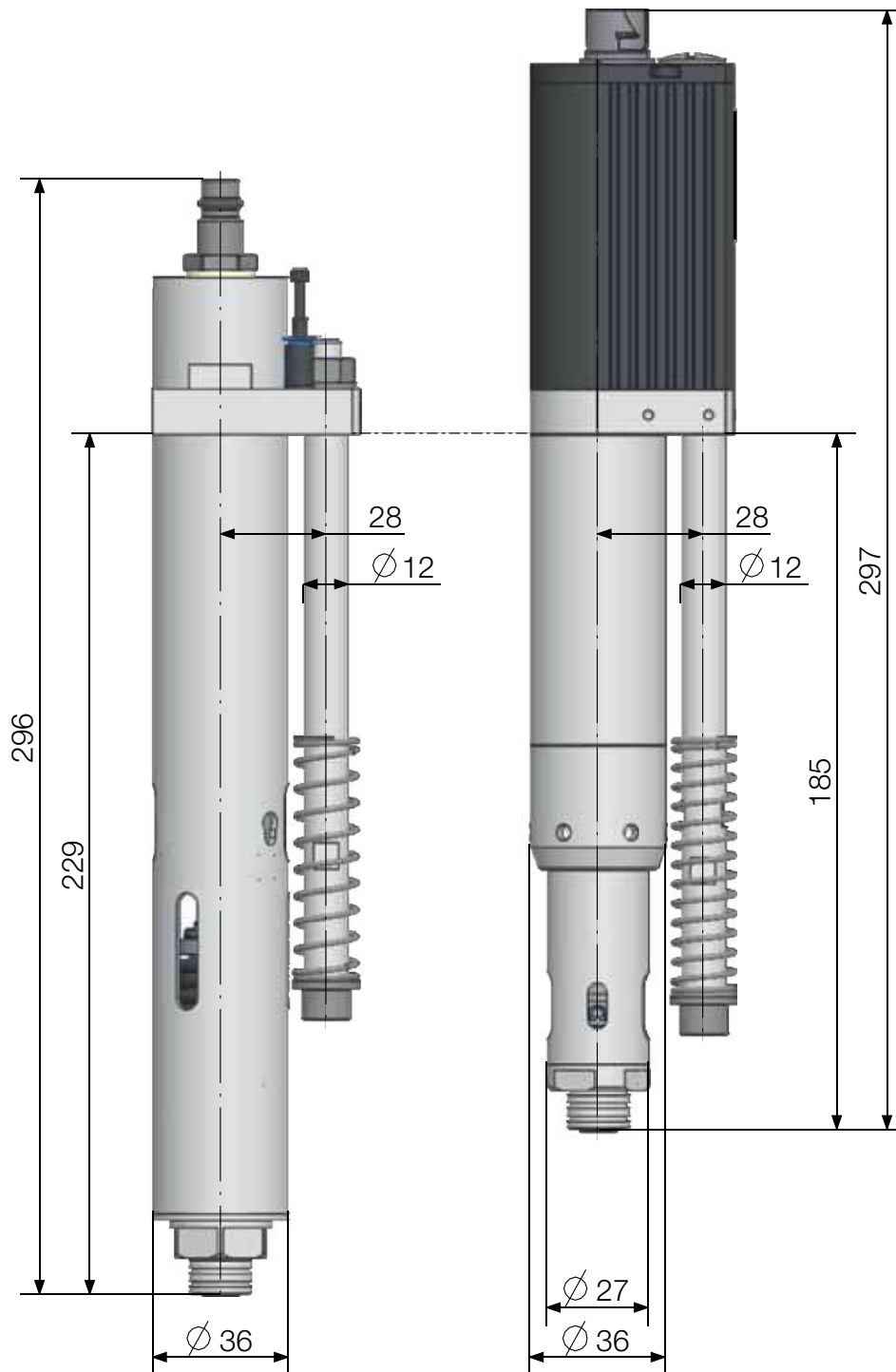

Our software solutions undergo continuous improvements. We recommend that you regularly update your software. In this way you will always receive the most up-to-date security updates, upgraded features and drivers. With the most current version of the software you can be sure that your device is optimally prepared for Industry 4.0.

DEPRAG

DEPRAG SCHULZ GMBH u. CO.

P.O. Box 1352, D-92203 Amberg, Germany
Carl-Schulz-Platz 1, D-92224 Amberg
Phone (+49) 9621 371-0, Fax (+49) 9621 371-120
www.deprag.com
info@deprag.de

CERTIFIED AS PER DIN EN ISO 9001
